



**Henan DASION Machinery CO.,Ltd**

**E-mail:**sales4@cndasion.com

**Address:**1509,pinganbaoxian,jingsanroad,jinshui street,zhengzhou,china

## **XBS and DXBS fine stone concrete pump**

**Keywords:** fine stone concrete pump,fine stone cement pump

Fine stone concrete pump or fine stone cement pump is a mortar conveying equipment, used for large-area and highly efficient construction of fine stone concrete or mortar stuffing in floor heating projects, and can be used with concrete transport trucks, shotcrete machine and concrete mixers.

### **Fine stone concrete pump application**

1. Widely used for conveying mortar or concrete
2. widely used for the conveying of fine stone concrete, fire-resistant and heat-insulating materials in various construction projects; the delivery of afforesting soil in eco-environmental construction; the pressure grouting of various basic piles.
3. The inner diameter of conveying pipe has developed into  $\Phi 100$  based on former  $\Phi 80$  so that XBS and DXBS series products can convey concrete with diameter no more than 30mm, which makes XBS and DXBS series products have broader applications such as the conveying of mortar, small stones and large aggregate concrete.

These concrete pumps are designed similarly to concrete pump trailer, we have XBS and DXBS models , also provide them in accordance with customer's requirements.

### **Fine stone concrete pump images**



**concrete mixer**



**batching plants**



**concrete trucks**



**trailer pump**



**gunite machine**



**WEB:**[www.concretemixerschina.com](http://www.concretemixerschina.com)

**E-mail:**sales4@cndasion.com



## Henan DASION Machinery CO.,Ltd

E-mail:sales4@cndasion.com

Address:1509,pinganbaoxian,jingsanroad,jinshui street,zhengzhou,china

### Fine stone cement pump features

1. High efficient hydraulic system with new high-speed commutation mode, which makes the pump commutation efficiency increase by 12%.
2. Large displacement pumping system makes the suction efficiency increased by 6%, to meet the needs of a variety of working conditions.
3. Overall hydraulic reversing open system has the advantage of high cleanliness of hydraulic oil, low oil temperature and small impact on commutation.
4. Master cylinder seal adopts waterproof technology, which can effectively prevent water from entering the hydraulic system, to prevent hydraulic oil emulsification.
5. Advanced S tube valve enjoys the advantages of good sealing, while quick-wear parts are economic and durable, easy to replace.
6. Hydraulic and electrical main components use internationally renowned brands with high reliability.

Hydraulically driven components are main parts of cement pumps, which is used for transporting or conveying concrete materials to the suitable containers.

### Fine stone cement pump drawings

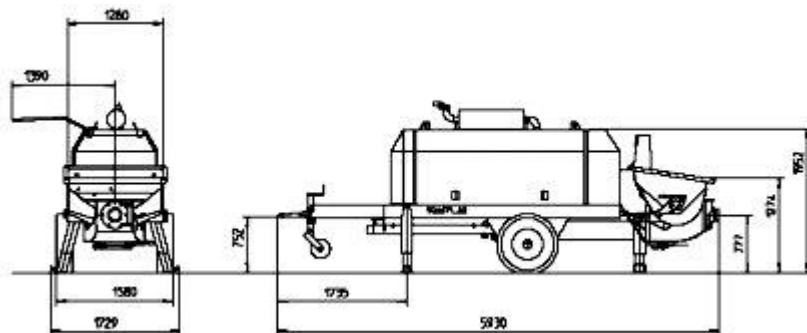

XBS and DXBS can be used with concrete mixers, concrete truck mixer and concrete batch plant, especially concrete shotcrete machine for highway road, concrete construction projects.

concrete mixer



batching plants



concrete trucks



trailer pump



gunite machine



WEB:[www.concretemixerschina.com](http://www.concretemixerschina.com)

E-mail:sales4@cndasion.com



**Henan DASION Machinery CO.,Ltd**

**E-mail:sales4@cndasion.com**

**Address:1509,pinganbaoxian,jingsanroad,jinshui street,zhengzhou,china**

**XBS Fine stone cement pump main technical parameters**

Items	Units	Models and Parameters		
		XBS25-12-33	XBS30-13-40	
Performance of The Machine	Theoretical Max. Discharging Volume	m³/h	25	30
	Theoretical Max. Delivery Pressure	Mpa	12	13
	Max. Delivery Frequency	times /min	24	30
	The Type of Distribution Valve		S valve	S valve
	Specification of Delivery Cylinder	mm	Φ140×800	Φ140×800
	Specification of Main Oil Cylinder	mm	Φ80/Φ50×800	Φ80/Φ50×800
	Outlet Opening Diameter	mm	Φ125	Φ125
	Hopper Capacity	L	300	300
Power System	Rated Voltage	V	~380	~380
	Main Motor Model		Y200L-4	
	Main Motor Power	Kw	30	37
	Rated Speed	r/min	1470	1470
	Assistant Motor Model		Y100L2-4	
	Assistant Motor Power	Kw	3	3
	Rated Speed	r/min	1430	1430
Hydraulic System	Hydraulic Oil Circuit Type		Open Circuit	Open Circuit
	Max. Oil Pressure of Pumping System	MPa	25	25
	Max. Oil Pressure of Mixing System	MPa	9	9
	Max. Mixing Speed	r/min	24	24
	Oil Tank Capacity	L	200	200
Other Parameters	Max. Diameter of Aggregates	mm	≤30 (≤20)	30
	Inner Dia. of Delivery Pipe	mm	Φ100/Φ80	Φ100/Φ80
	Dimension(Length ×Width ×Height)	mm	4100×1500×1500	4300×1500×1500
	Overall Weight	Kg	2000	2100
	Pulling Speed	Km/h	≤8	≤8

**concrete mixer**



**batching plants**



**concrete trucks**



**trailer pump**



**gunite machine**



**WEB:www.concretemixerschina.com**

**E-mail:sales4@cndasion.com**



**Henan DASION Machinery CO.,Ltd**

**E-mail:**sales4@cndasion.com

**Address:**1509,pinganbaoxian,jingsanroad,jinshui street,zhengzhou,china

**DXBS Fine stone concrete pump main technical parameters**

Items		Units	Models and Parameters	
			DXBS25-12-56	DXBS30-13-56
Performance Of the Machine	Theoretical Max. Discharging Volume	m³/h	25	30
	Theoretical Max. Delivery Pressure	Mpa	12	13
	Max. Delivery Frequency	times/min	24	30
	The Type Of Distribution Valve		S valve	S valve
	Outlet Opening Diameter	mm	Φ125	Φ125
	Hopper Capacity	L	300	300
	Main Motor Power	Kw	56	56
	Specification Of Delivery Cylinder	mm	Φ140×1200	Φ140×1200
	Specification Of Main Oil Cylinder	mm	Φ80/Φ50×1200	Φ80/Φ50×1200
Hydraulic System	Hydraulic Oil Circuit Type		Open Circuit	Open Circuit
	Max. Oil Pressure Of Pumping System	MPa	25	25
	Max. Oil Pressure Of Mixing System	MPa	9	9
	Max. Mixing Speed	r/min	24	24
	Oil Tank Capacity	L	200	200
Other Parameters	Max. Diameter Of Aggregates	mm	≤30 (≤20)	≤30 (≤20)
	Inner Dia. Of Delivery Pipe	mm	Φ100/Φ80	Φ100/Φ80
	Dimension (Length ×Width ×Height)	mm	4100×1500×1500	4300×1500×1500
	Overall Weight	Kg	2000	2100
Pulling Speed		Km/h	≤8	≤8

**concrete mixer**



**batching plants**



**concrete trucks**



**trailer pump**



**gunite machine**



**WEB:**www.concretemixerschina.com

**E-mail:**sales4@cndasion.com