



Henan DASION Machinery CO.,Ltd

E-mail:sales4@cndasion.com

Address:1509,pinganbaoxian,jingsanroad,jinshui street,zhengzhou,china

Batching plants spare parts

Keywords: cement silo,control system,screw conveyor,aggregate hopper

Batch plants system mainly includes mixing system, control system, automatic weigh system and aggregate loading system working with concrete truck mixers, concrete pump and other equipment. We also sell cement silo,control system,screw conveyor,aggregate hopper.

Cement storage silo

Cement silo is closed warehouse for store up powder material such as cement, fly-ash, foodstuff, etc. The silo is assembled with material level indicator to know how much inner material left, also assembled with pneumatic air brake system at the silo bottom, to avoid material blocking and discharging non-smoothly because of the gravity.

DASION plated cement silo, which is also called Separated cement silo or Sectionalsilo, is specially designed for long-term transportation, such as ocean shipping, railway transportation, etc. The series of silo can be easily loaded into containers, which can save much space and freight charge.

Cement storage silos are on-site storage containers used for the storage and distribution of various types of cement mixtures, and can be designed in a variety of sizes, widely used at many kinds of construction sites. A cement silo can be a permanent structure, or a portable model that can be relocated when necessary. We also produce portable cement silos which are easy to install and dismantled, and the components can be stored in a ware house until the device is needed at another building sites.

Cement storage silos are widely used with concrete batching plants, you can see them in every concrete batch plant areas. These play main role of construction projects.

Cement silo images

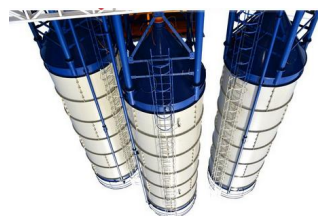

concrete mixer

batching plants

concrete trucks

trailer pump

gunite machine



WEB:www.concretemixerschina.com

E-mail:sales4@cndasion.com



Henan DASION Machinery CO.,Ltd

E-mail:sales4@cndasion.com

Address:1509,pinganbaoxian,jingsanroad,jinshui street,zhengzhou,china

Screw Conveyor

Screw conveyors are conveyor systems that transport bulk materials from one location to another, including conveying aggregate material, cement material, water and additional from cement silo or storage system to specification place.

Screw conveyors are also known as spiral conveyors, helix conveyors and centerless auger conveyors.

Main Features and Characteristics of Screw Conveyor

1. Adopt high-quality steel pipe with good integral rigidity.
2. Double pitches or three pitches design, which decrease the compression degree of material when being transported, and avoid blocking.
3. Adopt specially designed reducer for screw conveyor only, Hard finishing, level-one shifting, involute helical tooth, Stable transmission, low noise, large torque, suitable for bad environment work.
4. Adopt optional universal ball joint, which facilitates installation, adjustment and steering.
5. Inlet equipped with high-quality middle-hoisting bearing and tail bearing.
6. Sufficient spare parts with complete specification.
7. Large stock for common diameter of 168、219、273、323and 407,and dimension & angle can be customized according to your requirement.
8. Assembled by standard parts and components, which makes it convenient for transportation.
9. Screw conveyor manufacturers produce conveyors that consist of a rotating, spiral screw within a trough. The rotation of the screw pushes the materials through the trough to the intended destination. The trough is easily emptied and cleaned because of a removable cap that covers the intake end of the conveyor.

Screw conveyors images

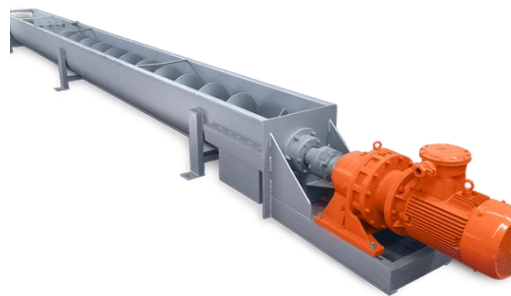

concrete mixer



batching plants



concrete trucks



trailer pump



gunite machine



WEB:www.concretemixerschina.com

E-mail:sales4@cndasion.com



Henan DASION Machinery CO.,Ltd

E-mail:sales4@cndasion.com

Address:1509,pinganbaoxian,jingsanroad,jinshui street,zhengzhou,china

Screw conveyors parts

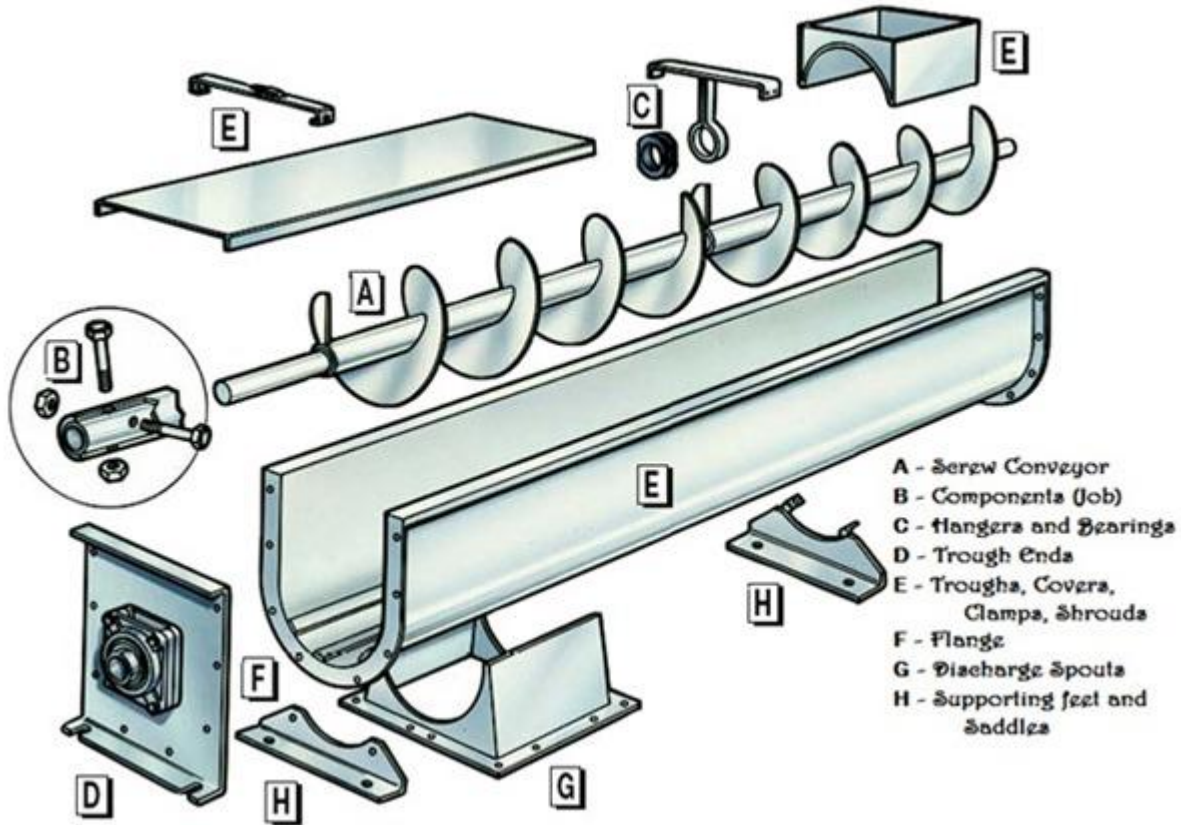

Aggregate loading system

Aggregate loading system is two or more aggregate hopper feeding different materials and mixture them together, and PLD series aggregate batching machine is ingredient machinery, which applies to construction sites, roads, bridges and other projects.

Aggregate hoppers can work with concrete mixers which discharging volume is below 6000L. The scaled aggregate can be fed directly into the concrete mixer by lifting hopper or conveyor belt. Aggregate batching machine weighing system uses weight control devices and sensors, can be quantified materials, ingredients and control, and automatically modify the gap.

concrete mixer



batching plants



concrete trucks



trailer pump



gunite machine



WEB:www.concretemixerschina.com

E-mail:sales4@cndasion.com



Henan DASION Machinery CO.,Ltd

E-mail:sales4@cndasion.com

Address:1509,pinganbaoxian,jingsanroad,jinshui street,zhengzhou,china

Main classification of PLD Aggregate Batching Machine

1. According to material quantity: 2 bins, 3 bins, 4 bins
2. According to measurement type: Various material by cumulative measurement, Each material by independent measurement
3. According to discharging method: Electrical conveyor belt, Pneumatic air cylinder

Aggregate loading system images



Control system

Control system is the center part of concrete batching plant, can operator the whole machine system, and control system is consisted of industrial PC, electric batching scale, operation console and high voltage cabinet.

Control system features

1. The characteristics are software and hard ware integration, good anti-interference ability, steady and reliable working and high batching precision.
2. The system adopts menu selection, which ensures the simple and convenient operation.
3. The system can also monitor and manage the material feeding, batching and mixing process during the production course and it is the optimal choice to improve the batching precision, improve the production management, ensure the equipment safety and increase the economic benefit.
4. Automatic mold, working with computer, improve safety performance
5. Durable resistance, one person or less people can operating the concrete batch plant
6. Imported by Italy, America and Germany etc.

concrete mixer



batching plants



concrete trucks



trailer pump



gunite machine



WEB:www.concretemixerschina.com

E-mail:sales4@cndasion.com